



77660

7766 Magnetic Door Position Switch



Surface Mount

Installation Instructions

1 Prepare frame for switch.

1a Prepare frame for surface installation of 7766 Switch.

Ⓢ **Note:** For maximum security, it is recommended that the switch be installed in the header, 2" from the lock stile edge.

1b Wire & install switch.

2 Prepare door for magnet.

2a Install magnet.

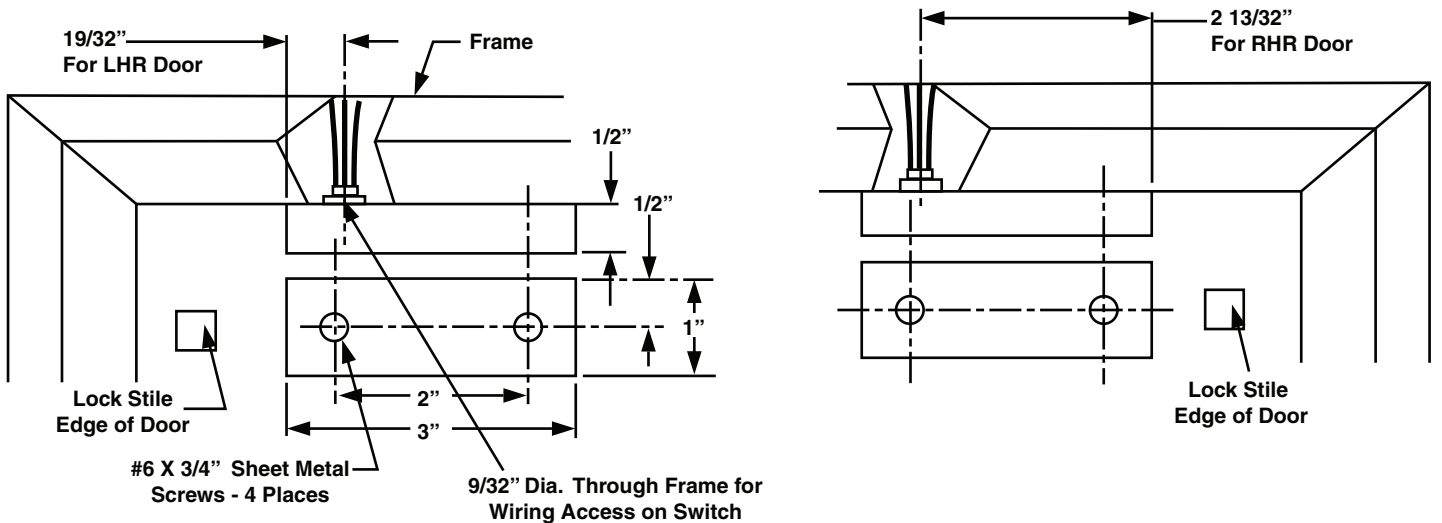

Check List

If switch does not work: check recommended gap and decrease if necessary.

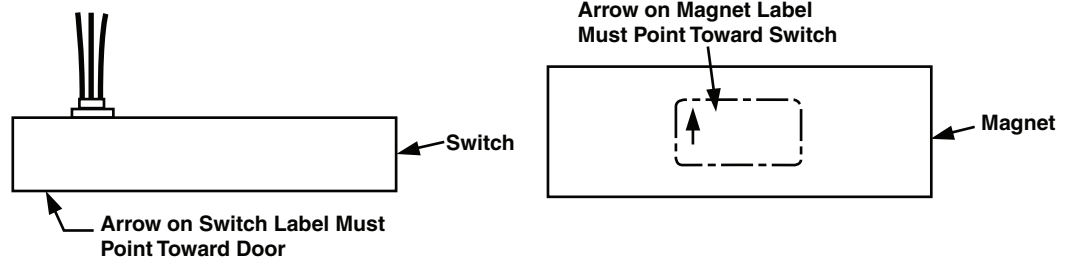

Overhead Mounting
(See note in Step 1-A of installation instructions)

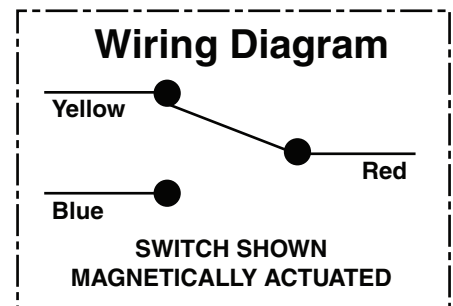
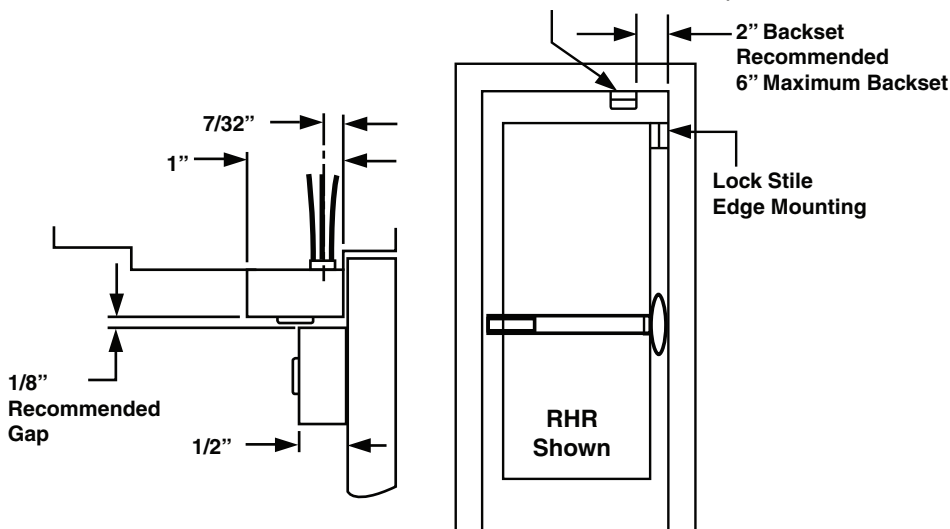

WARNING:
THESE ARE SIGNAL SWITCHES. NOT INTENDED FOR DIRECT SWITCHING.

Type	Current Rating
7766	.25 AMP

Typical Signalling Application

Magnetic Switch*

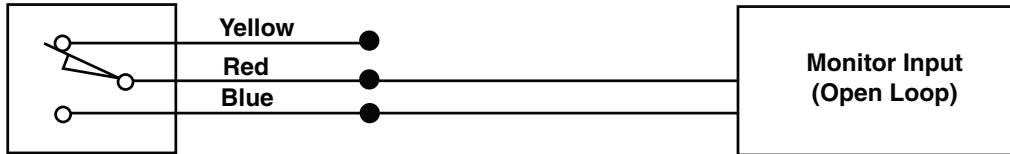

LED Panel Notes:

LED will light when door is open. If a lamp is used instead of an LED, limit current to .04 AMP.

Magnetic Switch*

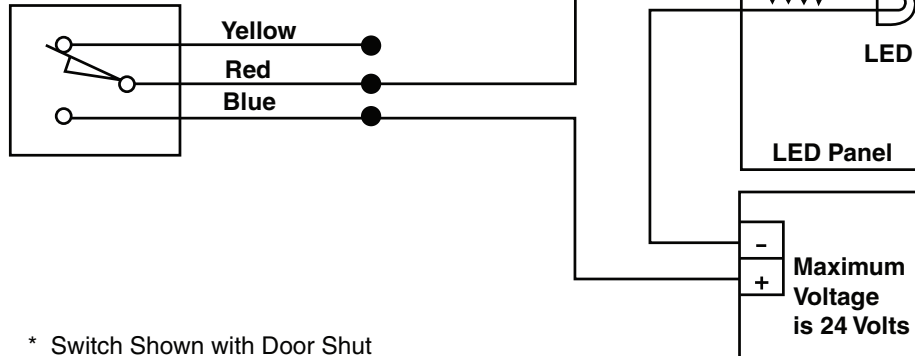

* Switch Shown with Door Shut

Typical Load Switching Application

Magnetic Switch*

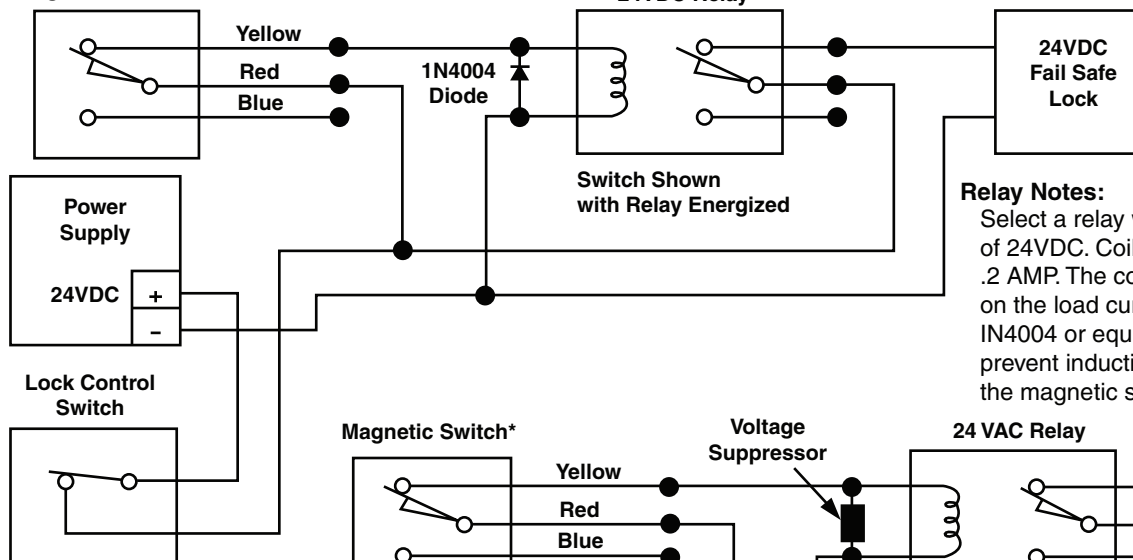

Relay Notes:

Select a relay with a coil voltage rating of 24VDC. Coil current is not to exceed .2 AMP. The contact rating is dependent on the load current requirements. An IN4004 or equivalent diode is used to prevent inductive EMF from damaging the magnetic switch contacts.

* Switch Shown with Door Shut

Magnetic Switch*

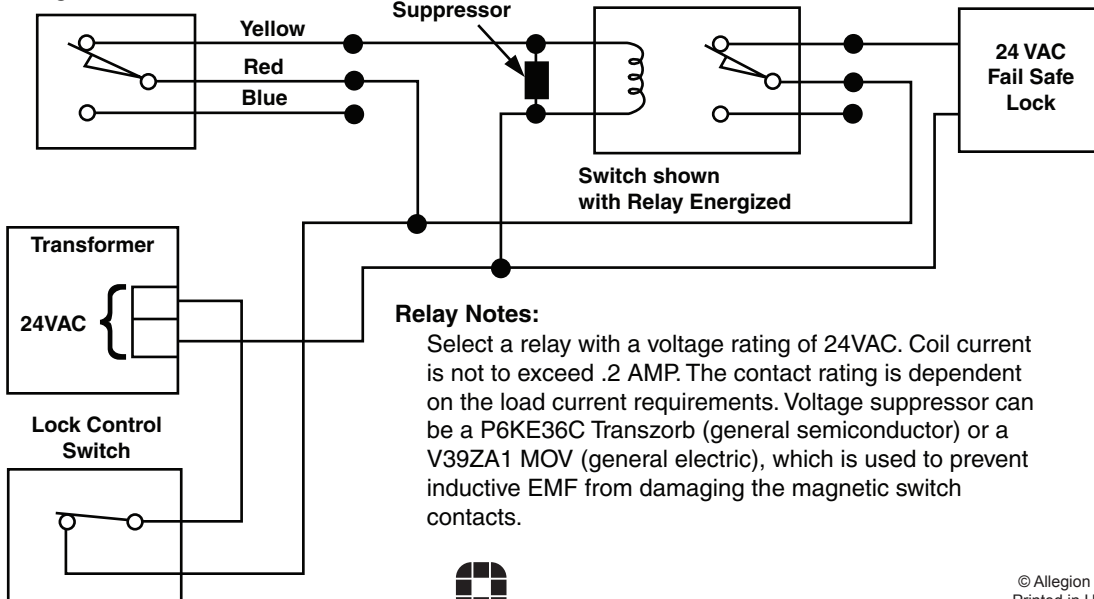

Relay Notes:

Select a relay with a voltage rating of 24VAC. Coil current is not to exceed .2 AMP. The contact rating is dependent on the load current requirements. Voltage suppressor can be a P6KE36C Transzorb (general semiconductor) or a V39ZA1 MOV (general electric), which is used to prevent inductive EMF from damaging the magnetic switch contacts.

Customer Service

1-877-671-7011

www.allegion.com/us

