



P513-611

B662/B762/B862



B-Series Double Cylinder Deadbolt
 Cerrojo Cilíndrico Doble Serie B
 Pêne Dormant à Double Cylindre
 de Série B

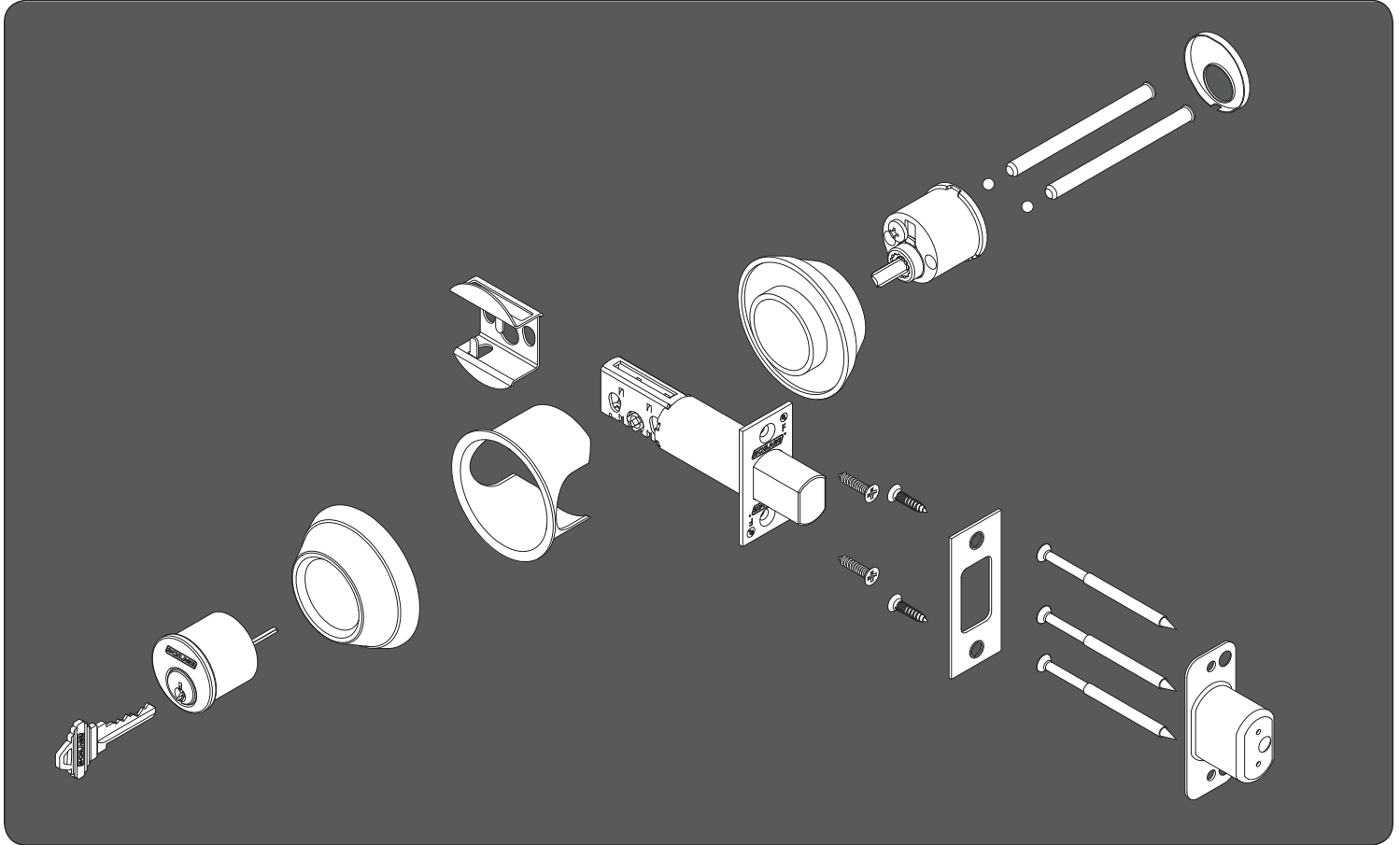

Installation Instructions
 Instrucciones de Instalación
 Instructions d'installation

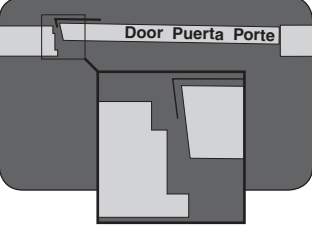
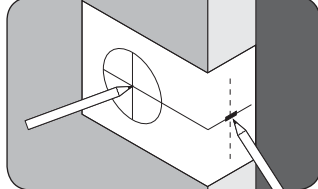

1 Mark door with template.
 Marque la puerta con la plantilla.
 Tracez la gabarit sur la porte.

A  **B** 

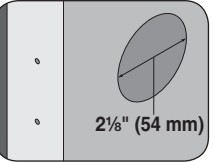
2 Drill 2 holes.
 Taladre (2) agujeros.
 Tracez la gabarit sur la porte.

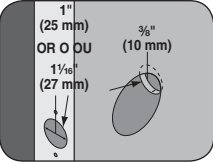
A   **B** 

- 1" (25mm) for deadbolt, or 1 1/16" (27 mm) for circular bolt
- 1" (25mm) para cerrojo de seguridad, o 1 1/16" (27 mm) para perno circular
- 25 mm (1 po) pour le pêne dormant, ou 27 mm (1 1/16 po) pour boulon rond

3 Install fire cup (2 1/8" through bore only)
 Instalar el protector contra incendios (solo núcleo pasante de 54 mm [2-1/8 pulg.]).
 Installez la coupole contre l'incendie (2 1/8 po à travers l'alésage seulement).

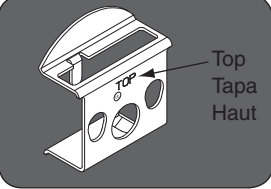
 Top
Tapa
Haut

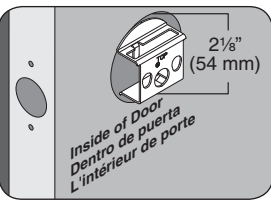
 2 1/8"
(54 mm)
Inside of Door
Dentro de puerta
L'intérieur de porte

4

Install deadbolt

Instalación del cerrojo de seguridad

Installez le pêne dormant

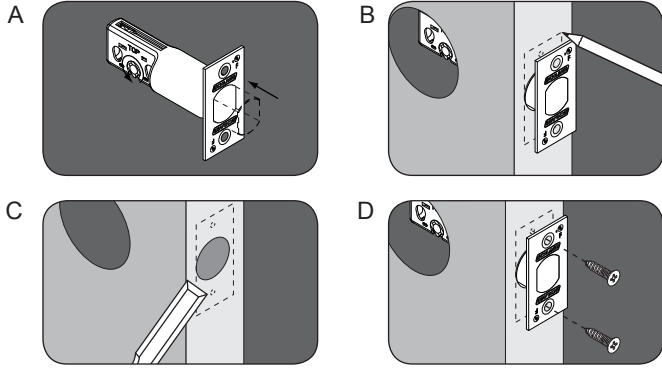

Install circular drive-in deadbolt.

Instale el cerrojo circular de seguridad.

Installez le pêne dormant circulaire.

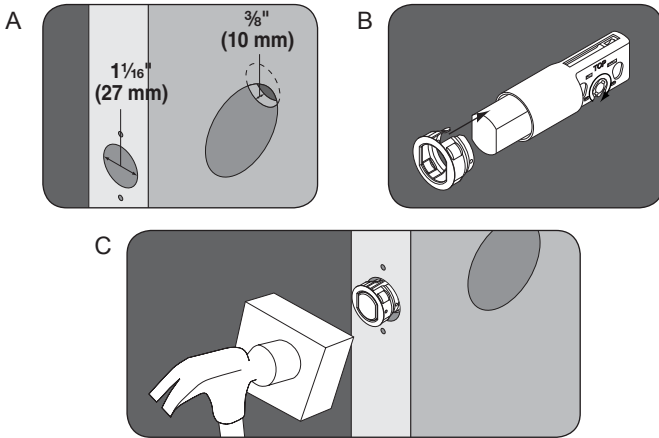

5 Prepare door jamb.

Prepare la jamba de la puerta.

Préparez le jambage de la porte.

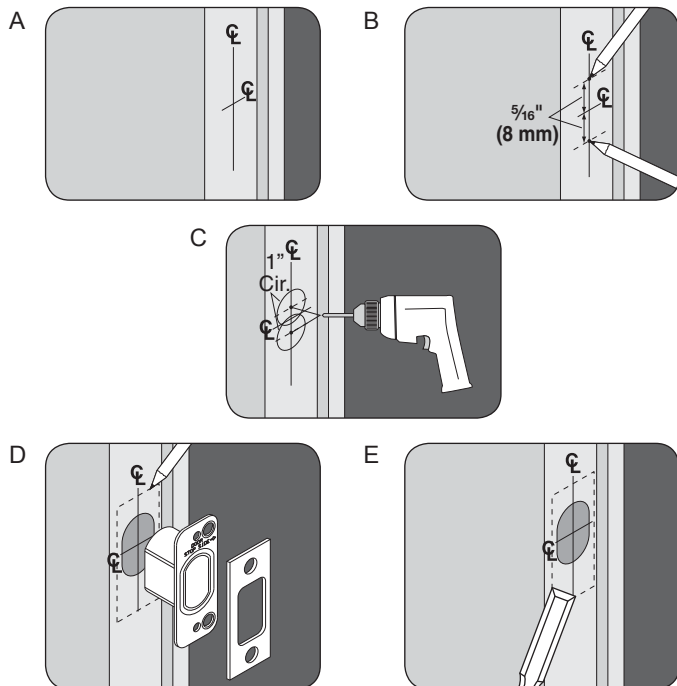

6 Install Strike Assembly.

Instale el conjunto de piezas del recibidor.

Installez les pièces de la gâche.

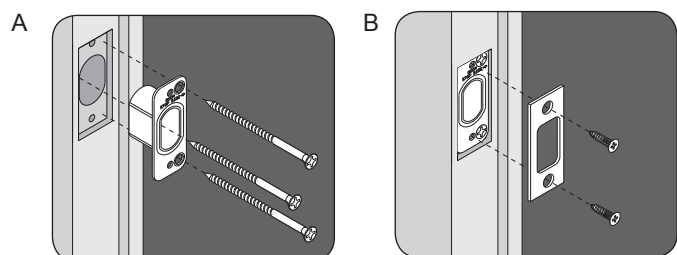

7 Install outside lock.

Instale la cerradura exterior.

Installez le verrou extérieur.

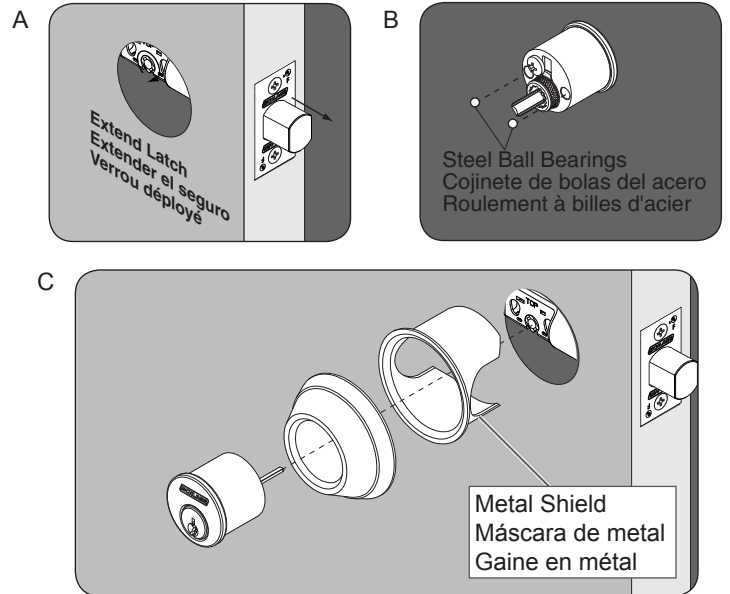

! IMPORTANT NOTES !

Do not use metal shield in existing 1 1/2" (38 mm) hole installations.

Si utiliza un agujero previamente taladrado de 38mm, no haga uso de la rodela metálica incluida.

S'il existe déjà un trou de 38mm, ne pas utiliser la gaine de sécurité fournie.

8 Install inside lock.

Instale la cerradura interior.

Installez le verrou intérieur.

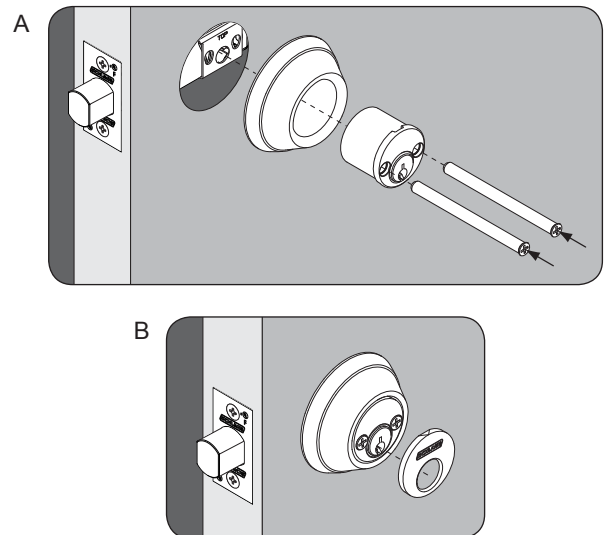

Customer Service Servicio al cliente Service à la clientèle

1-877-671-7011

www.allegion.com