



P516-096



# PIM400-TD2

User guide for Panel Interface Module PIM400-TD2

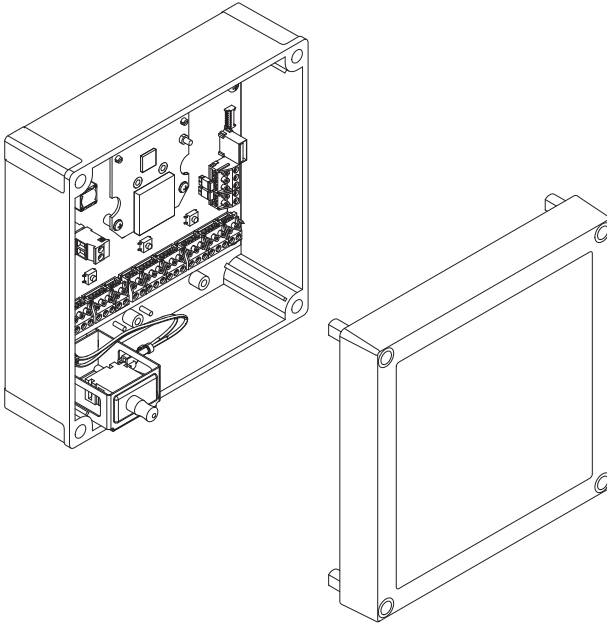

Para el idioma español, navegue hacia [www.allegion.com/us](http://www.allegion.com/us)  
Pour la portion française, veuillez consulter le site [www.allegion.com/us](http://www.allegion.com/us)

# Contents

Overview .....	3
Getting started .....	4
Features and components .....	5
Model specifications .....	6
Installation.....	6
Determine the location .....	6
Pre-installation test.....	6
Installation.....	7
Mount the PIM400-TD2.....	7
Wire routing.....	8
Cable/wire specifications .....	8
PIM400-TD2 to ACP connection .....	9
Typical PIM400-TD2 to ACP wiring diagram .....	9
Optional remote antenna .....	12
Link mode .....	12
Schlage Utility Software (SUS).....	12
Reset to factory defaults .....	12
DC power.....	13
Complete the installation .....	13
Troubleshooting .....	13
FCC/IC statements.....	14

To comply with FCC and Industry Canada RF radiation exposure limits for general population, the antenna(s) used for this transmitter must be installed such that a minimum separation distance of 20cm is maintained between the radiator (antenna) and all persons at all times and must not be co-located or operating in conjunction with any other antenna or transmitter.

This product is compliant of UL 294 and ULC S319 standard. This product's compliance would be invalidated through the use of any add-on, expansion, memory or other module that has not yet been evaluated for compatibility for use with this UL Listed product, in accordance with the requirements of the Standards UL 294 and ULC S319. This product has been evaluated for ULC-S319 Class I.

UL294 Access Control Levels tested to: Destructive Attack - Level 1; Line Security - Level 1; Endurance - Level 4; Standby Power - Level 1.

## Overview

This manual describes the operation and interaction of the Schlage PIM400-TD2 with Access Control Panels (ACPs) and Wireless Access Point Modules (WAPMs). The PIM400-TD2 is a product in the AD-400 Wireless Panel Interface Module (WPIM) category. The PIM400-TD2 is wired to the Access Control Panel.

- Connect the PIM400-TD2 to external power using a UL294 listed power supply for UL installations, and a ULC S318/ULC S319 listed power supply for cUL installations. Example power supplies include Schlage PS902, PS904, PS906.
- Installation location is determined by the location of the WAPM. The PIM400-TD2 is ideally installed very close to the access control panel.
- The PIM400-TD2 communicates to the WAPM(s) using radio frequency (RF).
- The WAPM is installed at the access point where access will be controlled and/or monitored.
- The PIM400-TD2 enclosure is NEMA type 4.

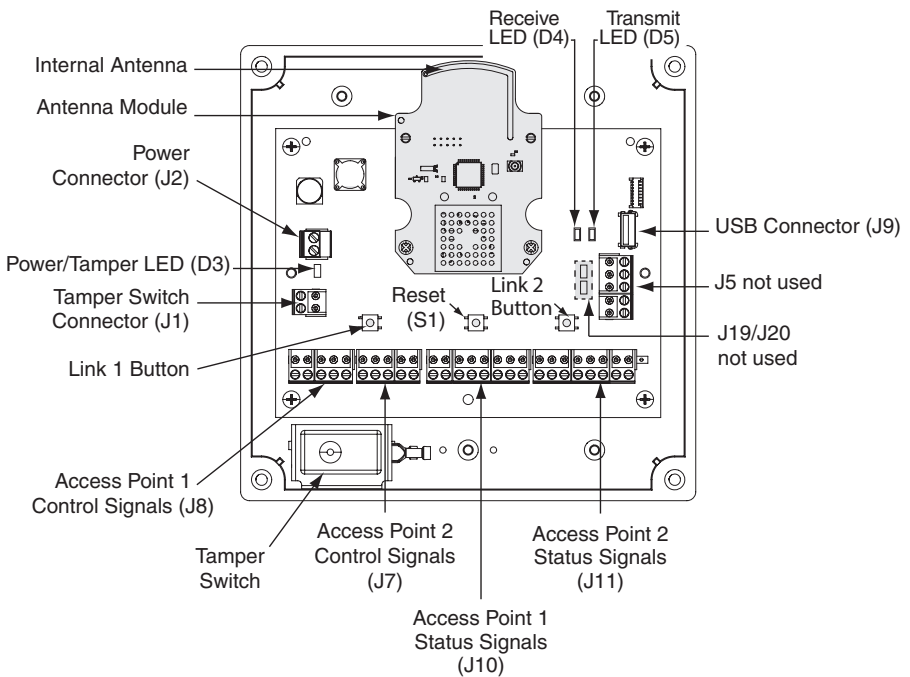

PIM400-TD2 printed circuit board assembly (PCBA)

## Getting started

The following is an overview of the steps required to set up the PIM400-TD2:

1. Install the WAPM (AD-400, WPR400, etc). See the installation guide that came with the WAPM or visit [www.allegion.com/us](http://www.allegion.com/us) for more information.
2. Make sure the PIM400-TD2 is located to allow for optimum RF signal transmission. See *Determine the location* on page 6 for more information.
3. Before installing the PIM400-TD2, check for proper communication function and linking with WAPM(s). See *Pre-installation test* on page 6 for more information.
4. The PIM400-TD2 has been evaluated for UL compliance in indoor applications only.
5. Make sure to follow unique installation procedures if installing on an indoor metallic wall. Refer to *Mount the PIM400-TD2 on page 7* for more information. Consult the Schlage Utility Software (SUS) user guide for information about configuring the PIM400-TD2 and the WAPM.
6. Familiarize yourself with the information contained in this user guide.

**This user guide is for the PIM400-TD2 only.**

**Save this user guide for future reference.**

## Features and components

Feature	Description
PIM400-TD2 status	Power and tamper status is indicated at the PWR/Tamper LED (D3). The LED is steady green when power is on and the tamper is inactive (cover is on), and blinking green when the tamper switch is activated (cover is off).
Access point link and status	The PIM400-TD2 overall status is communicated by a red/green LED for each access point. Red LEDs communicate real time and trouble status. The LED is <i>off</i> when the WAPM is <i>linked</i> ; the LED is <i>on</i> when the WAPM is <i>not linked</i> . Real time status: D40 = access point 1, D43 = access point 2 Trouble status: D1 = access point 1, D2 = access point 2 The PCB is marked with LED locators D1, D2, D40 and D43. Each access point has clock (CLK) and data (DATA) LEDs that indicate card and keypad data communication from the PIM400-TD2 to the ACP.
Reset switch	Press the reset switch (S1) if the PIM400-TD2 does not seem to operate properly.
Tamper switch	The tamper switch senses if the PIM400-TD2 enclosure cover is open or closed. If closed, the D3 LED is steady green and extended unlock works, if enabled. If open, the D3 LED is blinking green and extended unlock does not work even if enabled.

Component	Description
Access control panel connection	The PIM400-TD2 connects two WAPMs to the ACP. WAPM (Door) 1 connects through the access point 1 connections on J8 and J10 to the ACP, and WAPM (Door) 2 connects through the access point 2 connections on J7 and J11.
Power connector	The PIM400-TD2 power input (J2) is non-polarized. If power is lost or cycled, upon restoring power, the PIM400-TD2 will continue operation with the same configuration and linking information. <b>There is no need to re-configure or re-link.</b>

## Model specifications

Maximum number of WAPMs	Location	ACP interface/description
2	Indoor/outdoor	Magnetic (clock & data) or Wiegand (data 1/data 0)

## Installation

### Determine the location

The PIM400-TD2 communicates with WAPM(s) using radio frequency (RF) signals. RF signals are diminished by walls, distance, metal objects or barriers. Consider the following when placing the PIM400-TD2:

- Mount the PIM400-TD2 within 200 horizontal feet of each WAPM. When clear line-of-sight is available, communication may be possible up to 1000 feet.
- Do not mount the WAPM(s) and the PIM400-TD2 on different floors. The signal may be degraded and functionality could be severely limited.
- Do not mount the PIM400-TD2 on a metal surface. A separation of at least one inch must be maintained in all directions from any metal.
- Signal will not pass through metal walls or metal mesh in the walls (stucco). Use a remote antenna module located outside the room when necessary.
- Moving vehicles will interrupt the signal. Placement distance should be reduced by half when vehicles may temporarily block the signal.
- Mount the PIM400-TD2 or the remote antenna so that the antenna is vertical for optimal communication.

### Pre-installation test

Once locations for a PIM400-TD2 and WAPM(s) are determined, check performance prior to installation.

- ① **If using a remote antenna module, install the antenna as indicated in the ANT400 optional remote antenna module user guide.**
  1. As close as possible to its exact mounting location, temporarily mount the WAPM to the access control point (i.e. door, gate, elevator). Do not connect power yet.
- ① **The WPR400 may be used as a portable range tester to facilitate properly locating the PIM400-TD2.**
  2. Temporarily mount the PIM400-TD2 in the exact location and orientation it will be mounted.
  3. Power the PIM400-TD2 with a 12 or 24 VDC supply capable of delivering 250 mA.
  4. Put the PIM400-TD2 into link mode. Refer to *Link mode* on page 12.
  5. Go to the access point being tested. Make sure the access point is secure (closed).
  6. Connect the battery, or connect to a compatible UL294 or ULC S318/ULC S319 listed power supply.
  7. Verify that linking has occurred, indicated at the WAPM by the green LED flashing and optionally by an internal sounder beeping. The number of green flashes and audible beeps should be the same as the channel number to which the PIM400-TD2 is set.

## Installation

1. If linking occurred successfully, install the PIM400-TD2. Install and link additional WAPMs.
2. If linking was not successful, move the PIM400-TD2 six to ten inches (15.2 to 25.4 cm) in any convenient direction and repeat pre-installation test step 7 (see page 6), until all WAPMs link successfully. If still not successful, move the PIM400-TD2 closer to the WAPMs and repeat, or add more PIM400-TD2s.

If still not successful, RF interference may be the cause. Refer to the SUS user guide for information on changing the RF channel.

## Mount the PIM400-TD2

1. Remove the cover and place the PIM400-TD2 against the wall in the orientation where it successfully passed the pre-installation test.
  2. Mark the four (4) mounting hole locations on the wall with a pencil using the PIM400-TD2 enclosure as a template.
  3. Remove the PIM400-TD2 from the wall and drill the four holes ( $\frac{1}{16}$ " diameter drill bit recommended).
- ⓘ **If the wall does not adequately support the PIM400-TD2, wall anchors should be used.**
4. If mounted on a non-metallic surface or where no metal is within 1 inch (25 mm) of the back of the PIM400-TD2, use the #8 x  $1\frac{1}{2}$ " screws provided.
  5. If mounted on a metallic surface or where metal is within 1 inch (25 mm) of the back of the PIM400-TD2, attach the PIM400-TD2 1 inch (25 mm) from the wall.
- ⓘ **If a remote antenna is to be used, refer to the ANT400 optional remote antenna module user guide.**

## Wire routing

**IMPORTANT:** When drilling holes in the PIM400-TD2 to accommodate connectors, ensure that the drill bit does not damage any electronics inside the enclosure. Use light drill pressure to prevent the bit from entering the enclosure very far. The electronics may be removed before drilling holes. To remove electronics, remove only the four screws holding the circuit board to the enclosure. Do not loosen or remove any screws securing the electronics to the circuit board.

When using the internal antenna, attention to wire routing is very important. Improper wire routing will reduce the RF range. Wires inside the enclosure should be as short as possible (i.e. do not coil any excess wire inside the enclosure).

Drill hole(s) in the PIM400-TD2 enclosure to accommodate the size and number of entry/exit connectors to be used. Holes in the top of the PIM400-TD2 are for remote antenna installation only. **Do not run signal or power wiring through the top of the PIM400-TD2 enclosure.**

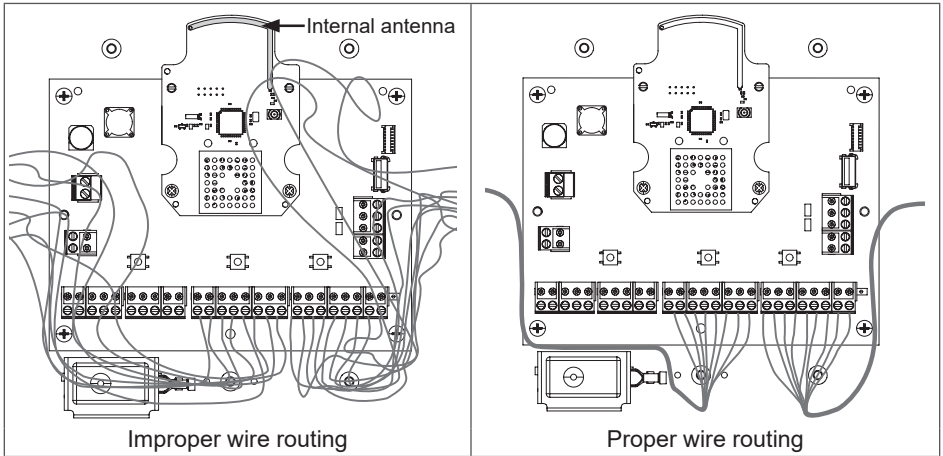

## Cable/wire specifications

Application	Part number	AWG	Description	Max distance
DC power input	Belden 8760 or equivalent	18	2 conductor	1000 Feet
PIM400-TD2 to ACP	Alpha 1298C or equivalent	22	8 conductor shielded	500 Feet



# PIM400-TD2 to ACP connection

**Review *Features and components* on page 5 before connecting the PIM400-TD2 to an ACP.**

**CAUTION:** Disconnect the ACP power and batteries while wiring the PIM400-TD2 to the ACP.

**WARNING:** Because every ACP is different, always check the panel's instruction manual for appropriate interface wiring.

- Use shielded cables for the signal wiring between the PIM400-TD2 and the ACP. For maximum wire lengths and cable specifications, refer to *Cable/wire specifications* above.
- For compliance with UL 294 or ULC S319, product must be used with a UL 294 or ULC S319 Listed access control panel or unit, respectively.
- Must be used with a UL294 or ULC S318/ULC S319 listed Power Supply capable of sourcing at least 250 mA @ 12 or 24 VDC (Schlage models PS902, PS904, PS906).

## Typical PIM400-TD2 to ACP wiring diagram

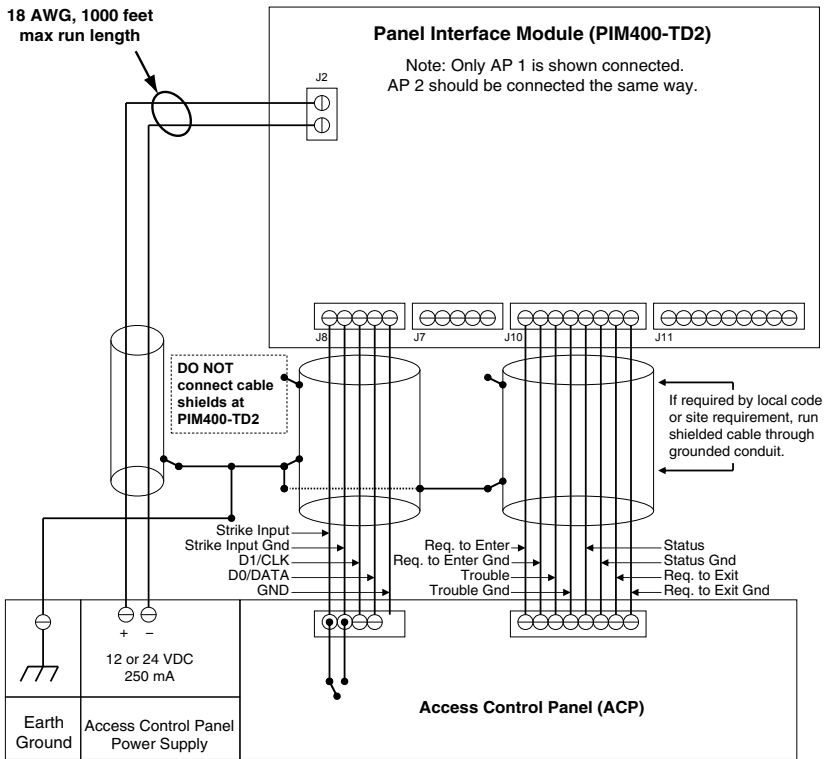

① **Unsupervised, ground switched inputs to panel shown. Some ACPs require supervised inputs and/or “dry/contact” isolated inputs. The optional Schlage dry contact relay board (RLBD) is available for these applications.**

① **The PIM400-TD2 can also be powered by the ACP power supply or a separate external power supply.**

## ACCESS CONTROL PANEL CONNECTIONS

Connector		PIM400-TD2 signal	ACP signal	Description/Explanation
J2		12V+	12 or 24 VDC	<p>PIM400-TD2 inputs for 12 or 24 VDC power.</p> <p>Draws 250 mA max.</p> <p>If the Access Control Panel (ACP) reader power outputs do not source enough current for the PIM400-TD2, use the ACP main regulated 12 VDC power supply or a separate UL294 or ULCS318/ULCS319 listed 12 or 24 VDC power supply.</p> <p>Power input is non polarized.</p>
J10 for Access Point A J11 for Access Point B	J10/J11 (1)	REQ TO ENTER	Request to Enter input signal	<p>PIM400-TD2 output indicating when the access point exterior door handle is making a request to enter.</p> <p>Connect to the ACP request to enter input.</p> <p>Connect only if the access point needs to have Request to Enter function.</p> <p>The request to enter signal polarity may be configured using the sus. This setting is shared with the request to exit signal.</p> <p>Output is pulled-up to 5 VDC and can sink 50 mA.</p>
	J10/J11 (2)		Request to Enter common contact (GND)	
	J10/J11 (3)	TROUBLE	General purpose alarm input signal	<p>PIM400-TD2 output indicating trouble is reported by the access point.</p> <p>Logic polarity is configurable using the SUS.</p> <p>Output is pulled-up to 5 VDC and can sink 50 mA.</p>
	J10/J11 (4)		General purpose alarm common contact (GND)	
	J10/J11 (5)	DOOR 1/2 STATUS	Door Status input signal	<p>PIM400-TD2 output indicates the position of the access point portal, open or closed.</p> <p>Connect only if the ACP needs to know the access point portal state.</p> <p>Logic polarity is configurable using the SUS.</p> <p>Output is pulled-up to 3.6 VDC and can sink 50 mA.</p>
	J10/J11 (6)		Door Status input common contact (GND)	

## ACCESS CONTROL PANEL CONNECTIONS

Connector		PIM400-TD2 signal	ACP signal	Description/Explanation
J10 for Access Point A J11 for Access Point B	J10/J11 (7)	REQ TO EXIT	Request to Exit input	PIM400-TD2 output indicating when the access point interior door handle is making a request to exit.  Connect to the ACP request to exit input.
	J10/J11 (8)		Request to Exit common contact (GND)	Connect only if the access point needs to have request to exit function.  The request to exit signal polarity can be configured using the SUS. This setting is shared with the request to enter signal.  Output is pulled-up to 5 VDC and can sink 50 mA.
	J11 (9)	+5V	5 VDC	RESERVED 5 VDC power supply pin for the RLBD, dry contact relay board.
J8 for Access Point A J7 for Access Point B	J8/J7 (1)	STRIKE INPUT	Normally Open strike relay contact	Strike input monitors the access panel strike relay.  Connect the STRIKE signal to the normally open terminal of the strike relay.
	J8/J7 (2)		Common strike relay contact	Connect the GROUND signal to the common terminal of the strike relay.  Connect only if the access point needs to be unlocked (door) or raised (gate).
	J8/J7 (3)	D1/CLK	Clock or Data 1 output	PIM400-TD2 outputs used to present card data to the ACP.  For an access point with a magnetic reader, will present clock and data signals to the ACP.  For an access point with a Wiegand or proximity reader, will present data1 and data0 signals to the ACP.
	J8/J7 (4)	DATA	Data or Data 0 input	If initial hookup fails to operate, switch wires at these terminals.  Output is pulled-up to 3.6 VDC and can sink 50 mA.
	J8/J7 (5)	GND	Signal ground	Common signal ground for the EXIT REQ, DOOR STAT, TROUBLE, DATA/D0 and CLK/D1 signals.

## Optional remote antenna

The PIM400-TD2 may be used with a remote antenna if:

- the PIM400-TD2 must be located in a remote, more serviceable or secure area, or
- it is necessary to increase the RF range.

Optional remote antenna models are shown below. For more information on remote antenna use and installation, refer to the ANT400 optional remote antenna user guide.

Optional remote antenna models			
Model	Enclosure	Location	Description
ANT400-REM-CEILING		Indoor	Optional remote omni-directional antenna (0 DB gain)
ANT400-REM-I/O	NEMA 4	Indoor/outdoor	Optional remote omni-directional antenna (0 DB gain)
ANT400-REM-HALL		Indoor	Optional remote bi-directional antenna (3.5 DB gain)
ANT400-REM-I/O+6dB	NEMA 4	Indoor/outdoor	Optional remote directional antenna (6 DB gain)

## Link mode

1. Press and release LINK 1 switch (SW2) to link access point 1, or LINK 2 (SW3) to link access point 2. The corresponding LED (LED1 for LINK1; LED2 for LINK2) flashes red and green. This indicates that the PIM400-TD2 is in link mode. To abort link mode, press the same switch again.
2. When the PIM400-TD2 is powered and in link mode, the system is ready for the WAPM to initiate linking.

Refer to the “Link” section of the user guide for the desired WAPM.

## Schlage Utility Software (SUS)

① **The Schlage utility software (SUS) is used for programming and setup only.**

The SUS is used to configure this device's links and outputs. For information about the SUS, see the Schlage utility software user guide.

## Reset to factory defaults

① **All configuration information will be deleted and the PIM400-TD2 will be reset to factory defaults!**

1. Remove the main cover.
2. Press and hold both link buttons for over 3 seconds.
3. Release both link buttons. The PIM400-TD2 will blink the red lights beside each link button while configuration reset takes place.
4. The two green lights beside the link buttons will blink 3 times when the reset is complete.
5. Replace the main cover.

## DC power

This connection is always required regardless of the system application or configuration. Refer to page 7 through page 9 for how to connect DC power to the PIM400-TD2.

## Complete the installation

After all required connections have been made, connect the power and ACP standby batteries (optional) to the panel.

## Troubleshooting

Problem	Possible cause(s)	Solution
The PIM400-TD2 does not communicate with the Access Control Panel (ACP).	Signal wiring connections with the ACP may not be properly connected.	Ensure that signal wiring at the PIM400-TD2 and at the ACP is properly connected. Refer to <i>PIM400-TD2 to ACP connection</i> on page 9 through page 11.  Check the ACP's instruction manual for appropriate interface wiring.  Note: Some ACPs require supervised inputs and/or "dry/contact" isolated inputs. The optional Schlage dry contact relay board (RLBD) is available for these applications.
The PIM400-TD2 does not communicate with Wireless Access Point Modules (WAPMs)	The antenna module may not be properly installed.	Ensure that the antenna module is installed and properly seated.
	Wiring may cause interference with the internal antenna on the antenna module.	Check to ensure that wiring is properly routed in the PIM400-TD2 enclosure and the area around the internal antenna is clear of any wire. See <i>Wire routing</i> on page 7 for more information.
	The PIM400-TD2 may not be linked to the WAPM(s).	Link the PIM400-TD2 to the WAPM. See <i>Link mode</i> on page 12 for more information. Also refer to the WAPM's user guide for link instructions.

## FCC/IC statements

The communication module is a 900 MHz transceiver for electronic locks and non-lock devices. The communication module links the access device to the Access Control Management System, with feedback control to the Access Device via a wireless means. The module contains the embedded firmware implementing the radio physical and data layers. There are 5 antennas approved for use with this module:

### Approved antenna list:

The required antenna impedance is 50 ohms.

1. PCB trace antenna with a 5.7dBi maximum gain
2. p/n: 23520587, dual beam antenna with a 3.5dBi gain (ANT400-REM-HALL)
3. p/n: 23530579, multi band directional panel antenna with 8.5dBi gain (ANT400-REM-I/O+dB)
4. p/n: 23530553, dual band quasi-omni panel antenna with 4.5dBi gain (ANT400-REM-I/O)
5. p/n: 23520561, multi band omni antenna with 2dBi gain (ANT400-REM-CEILING)

Antennas having a gain greater than the antenna type approved in the list are strictly prohibited for use with this device. However, antennas of the same type with a gain equal to or less may be used. Examples of this may include:

- a directional panel antenna with a gain equal to or less than 8.5 dBi may be used with this module
- an omni-directional antenna with a gain equal to or less than 2.0 dBi may be used with this module

### Specifications of the radio module:

Power output: 20 dBm

Modulation: BPSK-40

Operating frequency: 906 -924 MHz

**Note:** The intended use of this module is not for the general public. It is generally for industry/commercial use only. This transceiver is to be professionally installed in the end product by Allegion, and not by a third party. The Schlage XPB-COMAD400V3 900 MHz Communication Board Module will not be sold to third parties via retail, general public or mail order. In the case of a repair, the transceiver will be replaced by a professional installer.

### Federal Communication Commission interference statement

This equipment has been tested and found to comply with the limits for a Class B digital device, pursuant to Part 15 of the FCC Rules. These limits are designed to provide reasonable protection against harmful interference in a residential installation. This equipment generates uses and can radiate radio frequency energy and, if not installed and used in accordance with the instructions, may cause harmful interference to radio communication. However, there is no guarantee that interference will not occur in a particular installation. If this equipment does cause harmful interference to radio or television reception, which can be determined by turning the equipment off and on, the user is encouraged to try to correct the interference by one of the following measures:

- Reorient or relocate the receiving antenna.
- Increase the separation between the equipment and receiver.
- Connect the equipment into an outlet on a circuit different from that to which the receiver is connected.
- Consult the dealer or an experienced radio/TV technician for help.

This device complies with Part 15 of the FCC Rules.

Operation is subject to the following two conditions:

- (1) This device may not cause harmful interference, and
- (2) this device must accept any interference received, including interference that may cause undesired operation.

### FCC/IC caution

Any changes or modifications not expressly approved by the party responsible for compliance could void the user's authority to operate this equipment.

To comply with FCC/IC RF exposure limits for general population/uncontrolled exposure, the antenna(s) used for this transmitter must be installed to provide a separation distance of at least 20 cm from all persons and must not be collocated or operating in conjunction with any other antenna or transmitter.

### Industry Canada statements

This Device complies with Industry Canada License-exempt RSS standard(s). Operation is subject to the following two conditions:

- (1) this device may not cause interference, and
- (2) this device must accept any interference, including interference that may cause undesired operation of the device.

Under Industry Canada regulations, this radio transmitter may only operate using an antenna of a type and maximum (or lesser) gain approved for the transmitter by Industry Canada. To reduce potential radio interference to other users, the antenna type and its gain should be so chosen that the equivalent isotropically radiated power (e.i.r.p.) is not more than that permitted for successful communication.

This radio transmitter, 8053B-COMAD400V3, has been approved by Industry Canada to operate with the antenna types listed below with the maximum permissible gain and required antenna impedance for each antenna type indicated.

**Approved antenna list:**

The required antenna impedance is 50 ohms.

1. PCB trace antenna with a 5.7dBi maximum gain
2. p/n: 23520587, Dual Beam Antenna with a 3.5dBi gain (ANT400-REM-HALL)
3. p/n: 23530579, Multi band Directional Panel antenna with 8.5dBi gain (ANT400-REM-I/O+dB)
4. p/n: 23530553, Dual Band Quasi-Omni Panel Antenna with 4.5dBi gain (ANT400-REM-I/O)
5. p/n: 23520561, Multi band Omni Antenna with 2dBi gain (ANT400-REM-CEILING)

Antennas having a gain greater than the antenna type approved in the list are strictly prohibited for use with this device. However, antennas of the same type with a gain equal to or less may be used. Examples of this may include:

- a directional panel antenna with a gain equal to or less than 8.5 dBi may be used with this module
- an omni-directional antenna with a gain equal to or less than 2.0 dBi may be used with this module.

To comply with IC RF exposure limits for general population/uncontrolled exposure, the antenna(s) used for this transmitter must be installed to provide a separation distance of at least 20 cm from all persons and must not be collocated or operating in conjunction with any other antenna or transmitter.

**Customer Service**

1-877-671-7011 [www.allegion.com/us](http://www.allegion.com/us)



© Allegion 2023  
Printed in U.S.A.  
P516-096 Rev. 05/23-h